

STAGE SETS

PH SERIES

Combi Hoist



Lighting Hoist with a 3m to 12 long traveling connector strip / lighting bar assembly for up to 12 lighting circuits.

The modular Combi Hoist offers a wide range of design options for onstage electric hoists. The drive unit and diverter pulley are mounted to the ceiling or track mounted. The moving section of the Combi Hoist is connector strip / lighting bar assembly. The complete system is under static and dynamic conditions self-sustaining, which makes susceptible mechanical braking systems mandatory and reduces the maintenance requirements to a minimum. The radial winding drums eliminate any risk of cross winding during operation. The Combi hoist is UL tested and approved as a complete system.



Code	Travel	Safe Working Load	Max. Lighting circuits	
CH150F/200/4/3-6	3-6m	14m	200kg	9
CH150F/300/6/6-9	6-9m	14m	300kg	18
CH150F/500/8/9-12	9-12m	14m	500kg	24

*More length available on request

FOR ALL MODELS

UL (E217891) / CSA	
Voltage	208 / 400VAC (3-phase)
Lifting speed (average)	0.15 m/s
Lifting cable	4mm 7x19 galvanized carbon steel aircraft cable

Operating limits	2 adjustable limits
Over travel protection	Lower and upper limit (factory preset)
Slack wire detection	1 for each steel cable

Receptacles	Pin connector, Twist lock, U ground, Power connector on request
Cat's	DMX, RDM, Ethernet, Wire or Wireless Option on request



Motor Unit



Connector Strip

STAGE SETS

www.stage-sets.com

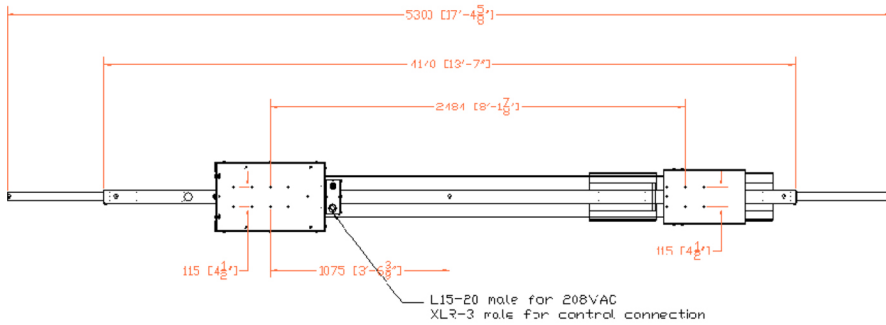
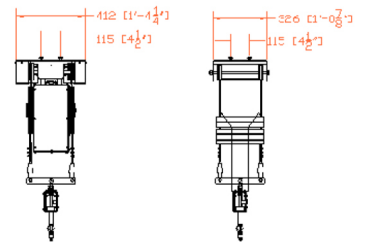
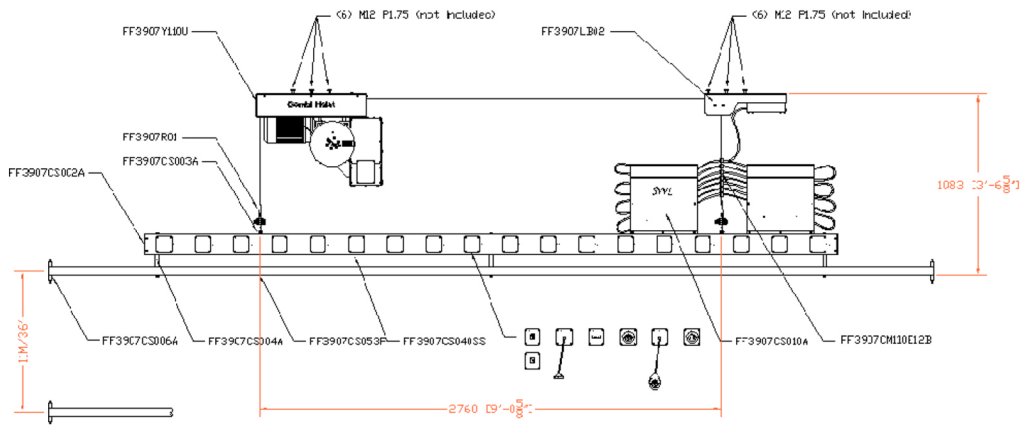

STAGE SETS

Tel: 55 8535 9810 / 55 1948 2269

www.stage-sets.com